

# Socay High Surge Micro Varistor

## SV1812N300G0B

### Features

- ◆ RoHS Compliant.
- ◆ Meet IEC 61000-4-5 standard.
- ◆ SMD type zinc oxide based ceramic chip.
- ◆ Insulator overcoat keeps excellent low and stable leakage current.
- ◆ Quick response time (<0.5ns).
- ◆ High transient current capability.
- ◆ High reliability.
- ◆ Compact size for EIA 1812.

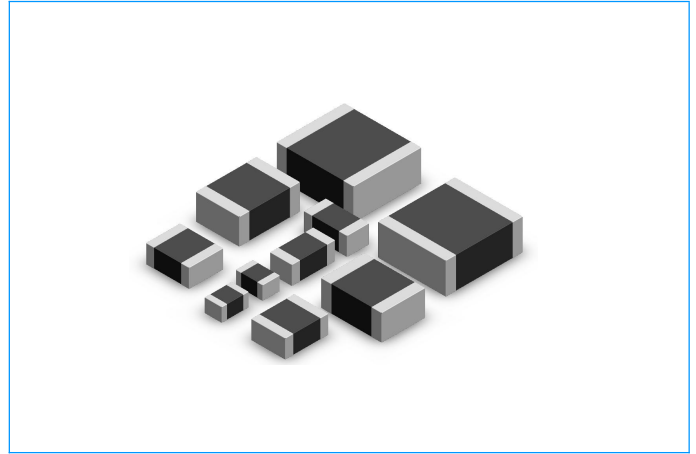

### Applications

- ◆ Protection against high working voltage applications  
Related transient over voltage.

### Equivalent Circuits

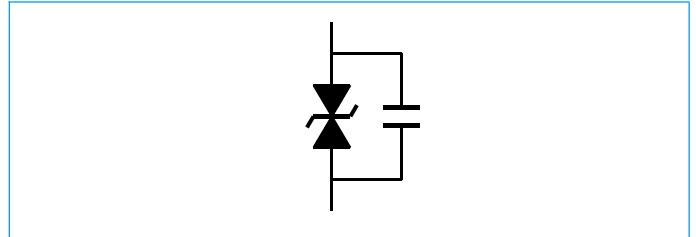

### Electrical Characteristics (25±5°C)

Symbol	Minimum	Typical	Maximum	Units
$V_{RMS}$	—	—	21	V
$V_{DC}$	—	—	30	V
$V_V$	37	—	46	V
$V_C$	—	—	70	V
$C_P$	—	1900	—	pF
$I_{max}$	—	—	800	A

#### Notes:

$V_{RMS}$  - Maximum AC operating voltage the varistor can maintain and not exceed 10μA leakage current.

$V_{DC}$  - Maximum DC operating voltage the varistor can maintain and not exceed 10μA leakage current.

$V_V$  - Voltage across the device measure at 1mA DC current.

Equivalent to  $V_B$  "breakdown voltage".

$V_C$  - Maximum peak current across the varistor with 8/20μs waveform and 5A pulse current.

$C_p$  - Device capacitance measured with zero volt bias 1Vrms at 1KHZ .

$I_{max}$  - Maximum peak current which may be applied with 8/20μs waveform without device failure.

# Socay High Surge Micro Varistor

## SV1812N300G0B

### Construction & Dimensions

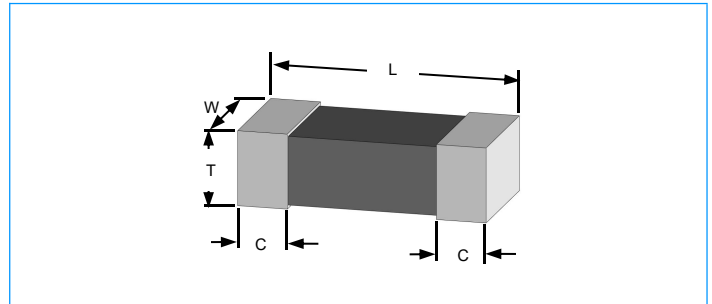
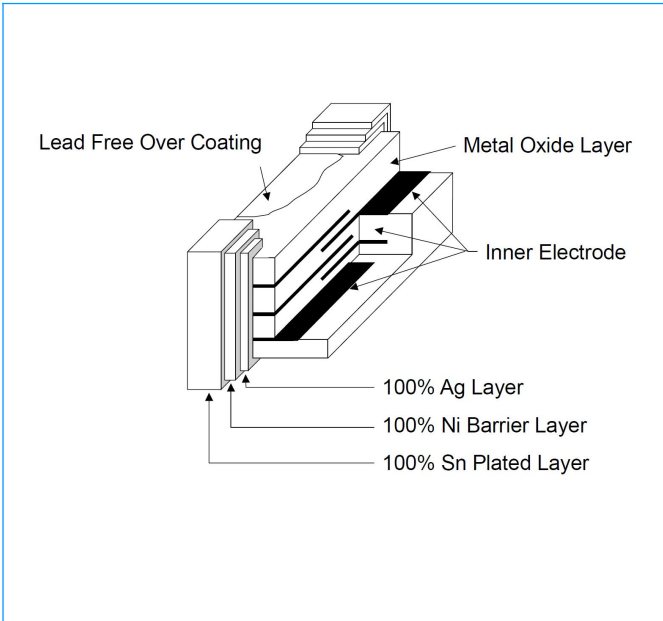

Size EIA (EIAJ)	1812 (4532)
Symbol	Millimeters
L	4.50±0.40
W	3.20±0.30
T	2.5 Max
C	0.60±0.30

### Pad Layouts & Precaution for handling of substrate

#### Solder cream in reflow soldering

Refer to the recommendable land pattern as printing mask pattern for solder cream.

(1) Print solder in a thickness of 150 to 200µm

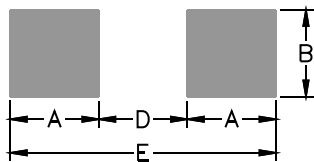

#### Precaution for handling of substrate

Do not exceed to bend the board after soldering this product extremely. (reference examples)

- Mounting place must be as far as possible from the position, which is close to the break line of board or on the line of large holes of board.
- Do not bend extremely the board, in mounting another component. If necessary, use back-up pin (support pin) to prevent from bending extremely.
- Do not break the board by hand. We recommend to use the machine or the jig to break it.

Size EIA (EIAJ)	1812 (4532)
Symbol	Millimeters
A	1.5
B	3.6
D	3.0
E	6.0

# Socay High Surge Micro Varistor

SV1812N300G0B

## Soldering Parameters

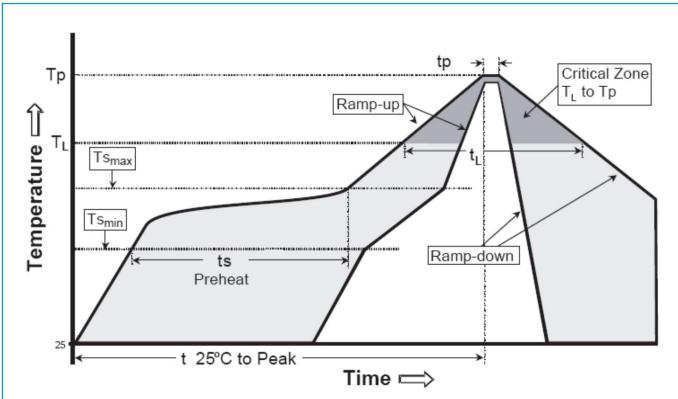

## Precaution for Soldering

Note that this product will be easily damaged by rapid heating, rapid cooling or local heating.  
Do not give heat shock over 100°C in the process of soldering.  
We recommend to take preheating and gradual cooling

### Soldering gun procedure

- Note the follows, in case of using solder gun for replacement.
- 1) The tip temperature must be less than 350°C for the period within 3 seconds by using soldering gun under 30W
  - 2) The soldering gun tip shall not touch this product directly.

### Soldering volume

Note that excess of soldering volume will easily get crack the body of this product.

Reflow Condition		Pb-Free assembly
Pre Heat	-Temperature Min ( $T_{s(min)}$ )	+150°C
	-Temperature Max ( $T_{s(max)}$ )	+200°C
	-Time (min to max) ( $t_s$ )	60 -180 Seconds
$T_{s(max)}$ to $T_P$ - Ramp-up Rate		3°C/Second Max
Reflow	- Temperature ( $T_L$ ) (Liquidus)	+217°C
	- Time (min to max) ( $t_L$ )	60 -150 Seconds
Peak Temperature ( $T_P$ )		260 °C
Time within 5°C of actual peak Temperature ( $t_p$ )		20-40 Seconds
Ramp-down Rate		6°C/Second Max
Time 25°C to peak Temperature ( $T_P$ )		8 minutes Max

## General Technical Data

Operating Temperature		-40 ~ +125°C
Storage Temperature		-40 ~ +125°C
Response Time		<1 ns
Solderability		245±5°C, 5 +0/-0.5sec
Solder leach resistance		260±5°C, 10±1sec
Taping Package Storage Condition	Storage Temperature	5 ~ 40°C
	Relative Humidity	To 65%
	Storage Time	12 Months max

# Socay High Surge Micro Varistor

## SV1812N300G0B

### Packaging Information

#### Carrier Tape Dimensions

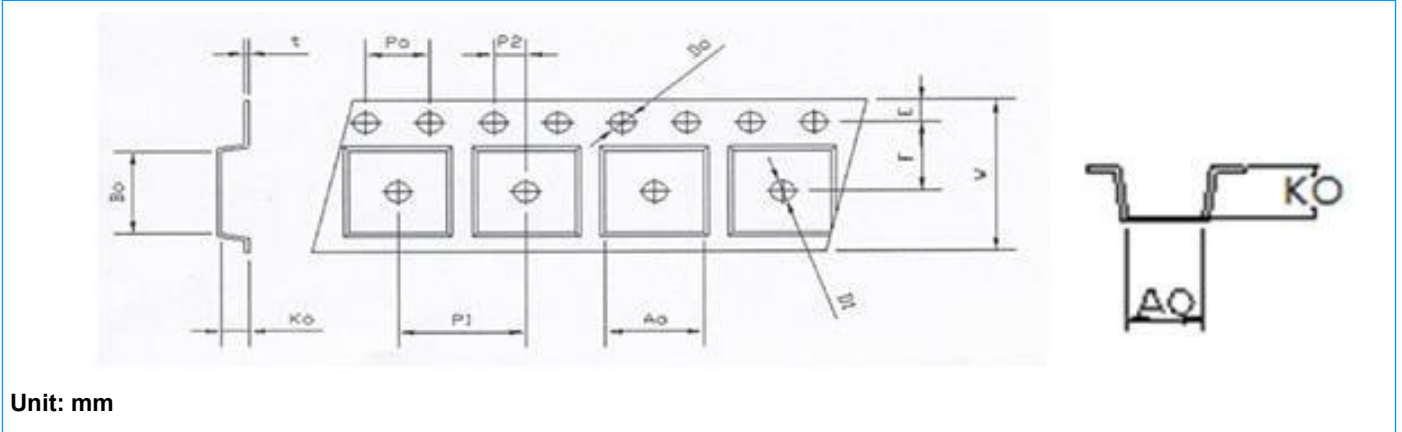

Unit: mm

Symbol	W	E	F	D0	D1	P0	P1	P2	10P0
1812	12.0±0.15	1.75±0.10	5.5±0.10	1.55±0.10	1.55±0.10	4.0±0.10	8.0±0.10	2.0±0.10	40.0±0.20
Symbol	Bo	Ao	Ko	t	--	--	--	--	--
1812	4.9±0.10	3.5±0.10	2.2±0.10	0.25±0.5	--	--	--	--	--

#### Taping Reel Dimensions

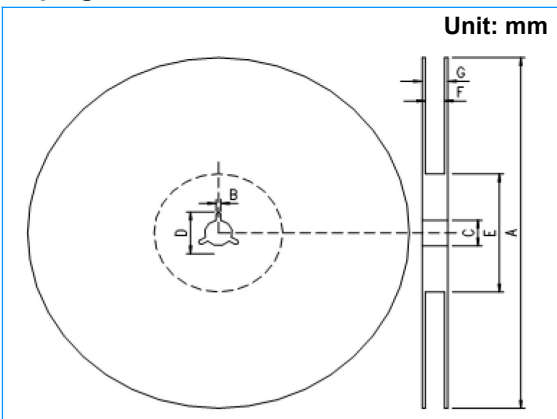

Symbol	A	B	C	D	E	F	G
1812	178.0±1.0	2.5±0.5	13.0±0.5	25.0±1.0	60.2±0.5	13.0±0.5	16.0±0.5

#### Taping Specifications

There Shall be the portion having no product in both the head and the end of taping, and there shall be the cover tape in the heat of taping.

#### Quantity of products in the taping package

SIZE EIA (EIAJ)	1812 (4532)
Standard Packing Quantity (PCS / reel)	1,000